

# Conder CNSB Bypass Separator: Granular Surround

## Premier Tech Aqua Installation Guidelines

Ref: UTG9504

Revision No. 3

### General

1. These guidance notes refer only to the installation of granular surround CNSB Bypass Separators Manufactured to BS EN 858 Class 1 and Class 2.
2. These guidance notes cannot provide specific, site-related installation instructions.
3. If in any doubt whatsoever about any aspect of the installation please contact Premier Tech Aqua on 0870 264 0004.

### Pre-Installation Inspection

1. The filter pod in these tanks is held in place during transportation by means of a Transit Brace. This is to hold the filter pod in place during transportation and ensure the separator is delivered to site in the same A1 condition as it left our manufacturing facility. **THIS MUST BE REMOVED PRIOR TO INSTALLATION.** Failure to remove the brace may prevent access to the pod for maintenance and **WILL RENDER THE WARRANTY ON THE TANK INVALID.**
2. The timber transit brace consists of a vertical brace holding the filter pod in place and a horizontal restraining bar. To remove the brace, unscrew the horizontal restraining bar and remove both pieces of timber
3. Tanks should be subject to a visual inspection prior to installation
4. Check the tank is the correct size and duty, see label on tank
5. Any damage should be notified to the delivery driver and to Premier Tech Aqua Ltd on 0870 264 0004.
6. Do not attempt to carry out any unauthorised repairs, as this will invalidate the warranty on the tank.
7. Check for, fractures to the shell or ribs, delaminations, scratches or abrasions deeper than 1.5mm, stress cracks or star crazing.
8. Check invert depth is correct and inlet and outlet pipe orientations are correct

### Transportation, Unloading and Storage of Tanks

1. Tanks must be held down during transportation using nylon straps, do not use cables or chains to hold tank.
2. Do not over tighten straps to cause deformation of the tank shell.

3. Tanks are best lifted by crane and webbing lifting straps – do not use chains or wire ropes in contact with the tank.
4. Premier Tech Aqua recommends the use of a lifting beam for tanks longer than 8 meters.
5. Smaller tanks may be lifted with other suitable site equipment but greater care is needed to control the lift and to ensure the tank is not damaged.
6. Move tanks only by lifting and setting, do not drag or roll.
7. Do not drop or roll tanks from truck.
8. Tanks are provided with feet, place tanks carefully onto a smooth level even surface, free from rocks, large stones or other debris that could cause point loads.
9. Do not fill tanks or ballast with water whilst above ground, tanks are dependent upon support from the backfill material to maintain the watertight integrity of the tank.
10. In high wind conditions, consideration should be given to strapping down the tanks to prevent damage.

### Service Specification

1. These tanks are designed to be installed below ground and completely surrounded with pea gravel or crushed stone.
2. Generally, the depth from finished ground level to the top crown of the main shell should be no more than 2 metres. This may vary dependent upon ground water conditions.
3. Deeper inverts may be accommodated on a standard shell providing the water table level does not exceed 2 metres above the top crown of the main shell.
4. For deeper burial with high water table conditions heavy duty shells are available.
5. Should you be in any doubt regarding suitable shell application please call our sales number 0870 2640004. If the tank is installed outside these parameters it may suffer irreparable damage.

### Excavation Size

1. Excavation should be planned with due regard to Health and Safety requirements, and should be either shored or battered back to a “safe” angle. The excavation should allow a minimum 450mm clearance between tank sides and ends and the excavation wall or face of shoring. 450 mm minimum is also required between adjacent tanks.

- Native soils with low bearing capacity (equivalent to less than 12 SPT blow counts) will require clearance to tank wall increased up to half the tank diameter.
- Terram Filter Fabric may be required to prevent migration of backfill material.

### Loadings

- If the tank is installed in an area where traffic or other superimposed loadings can be applied, consult a structural engineer for the design of a reinforced concrete slab to prevent the load being transmitted to the tank.

### Buoyancy & Anchoring

- Where depth of cover over the tank exceeds 70% of the tank diameter, it will not require mechanical anchoring in worst case conditions of empty tank with tank pit flooded to ground level. If depth of cover is less than this, then mechanical anchoring is required for worst case conditions. Two methods are possible:

#### a) Reinforced Concrete Anchor Slab

Reinforced concrete anchor slab of minimum thickness 200 mm, sized to cover the excavation area. The slab should incorporate Premier Tech Aqua webbing anchor straps.

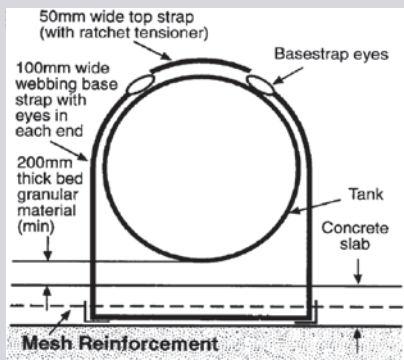

#### b) Concrete Deadman Anchors

Reinforced (two 20mm steel bars) concrete beam (pre-cast or in situ) each side of the tank of equal length to the tank, and with section as shown below. Use Premier Tech Aqua's webbing anchor straps as illustrated below:

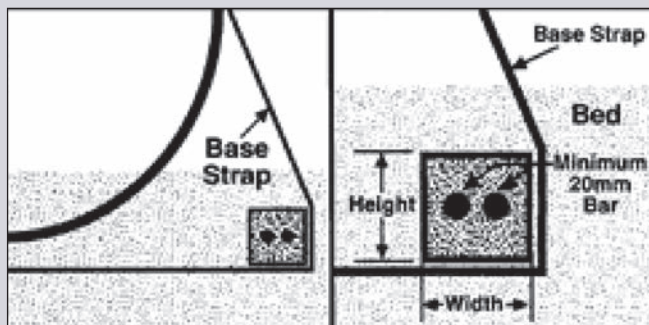

### Deadman Size

Tank Diameter (mm)	Minimum Height (mm)	Width (mm)
1800	300	300
2500	300	300
3000	300	450
4000	200	900

### Deadman Should Not Lie in Tank Shadow

If maximum water table can be determined at lower than ground level, then the requirement for anchoring can be reviewed – contact Premier Tech Aqua for details.

### Primary Backfill

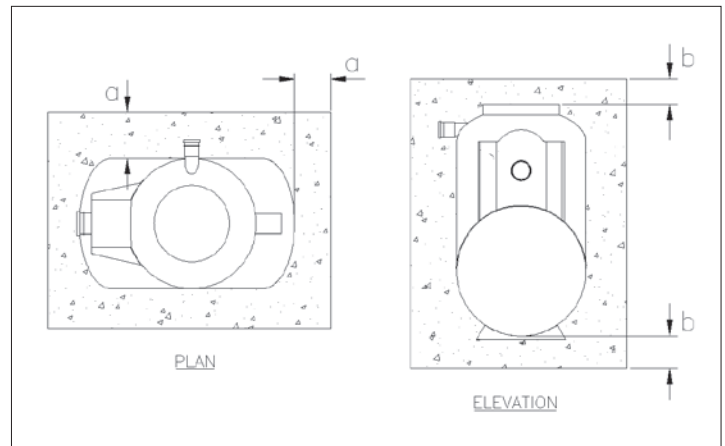

- Tanks must be installed with Primary Backfill only within the region immediately surrounding the tanks.
- This Primary Backfill must extend a minimum distance from the tank as shown in the table below.

Tank Diameter (mm)	'a' Minimum (mm)	'b' Minimum (mm)
1000	300	300
1200	300	300
1500	300	300
1800	300	300
2500	300	300
3000	450	450
4000	450	450

## Primary Backfill Specification

1. Primary Backfill material should be free-flowing granular material and can be:
  - a) Rounded Pea Gravel, min particle size 3mm, maximum 18 mm, compacted to a relative density of >70%.
- Or
- b) Crushed or Processed Stone, minimum particle size 3 mm, maximum 12 mm, compacted to a relative density of >40%.
2. No more than 5% may pass a 2.36mm sieve size.
3. Dry Gravel density must be at least 1500 kg/m<sup>3</sup>.
4. The following materials are approved as Primary Backfill:

a) Pea Gravel

- Naturally rounded aggregate with particle size not less than 3 mm and not greater than 18mm.
- Pea gravel shall be clean and free flowing, free from large rocks, dirt, sand, roots, organic materials or debris.
- Upon screening analysis the backfill material shall have no more than 5% by weight passing 2.38 mm sieve.

b) Crushed Stone

- Crushed stone or gravel with particle size not less than 3 mm and not greater than 12 mm, aggregate shall be clean and free flowing, free from large rocks, dirt, sand, roots, organic materials or debris.
- Material should be washed or screened to remove fine particles.
- Upon screening analysis the backfill material shall have no more than 5% by weight passing 2.38 mm sieve
- Use of other than specified backfill and bedding materials will void the tank warranty.

NOTE: All backfill material shall be free of ice and snow at time of installation. Backfill material shall not be frozen or contain lumps of frozen material at any time during placement.

- Compaction should be by lightweight rollers or vibratory plate compactor until "traffic" depth has been achieved. Compact evenly around the turret extensions to reduce risk of distortion.

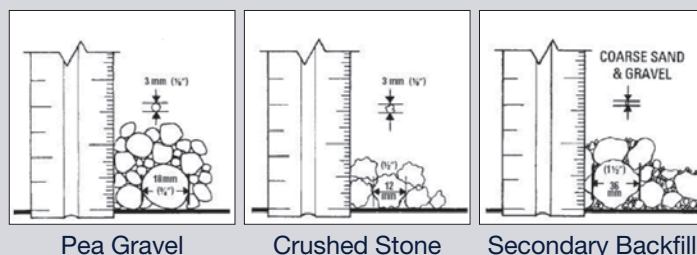

## Control of Groundwater

1. Tanks must not be subjected to buoyant forces during installation, taking account of ground water levels and surface water run-off, and their accumulation in the tank pit, even if tanks are anchored.
2. The excavation should be maintained dry by pumping or whatever suitable means until the installation is complete.

## Secondary Backfill Specification

1. Secondary backfill shall not be used adjacent to the tank.
2. Secondary Backfill may be used only outside of the primary backfill;
3. The following are approved as Secondary Backfill materials:
  - a) Coarse Sand or Gravel
    - Coarse sand or gravel containing rocks no larger than 36 mm on largest dimension.
    - Backfill shall be clean and free flowing, free from dirt, clay, fine sand, roots, organic materials or debris.
    - Upon screening analysis this backfill material shall have no more than 5% by weight passing 0.075mm sieve.
    - During placement this backfill material must be compacted to 95% Relative Compaction.
  - b) Select Native Backfill
    - Clean native backfill, or clean selected backfill, containing rocks no larger than 36 mm on largest dimension. This material must be compacted to 95% Relative Compaction.
    - The quality of this backfill material shall be such that it exhibits an ultimate bearing strength in excess of 170 kPa in the compacted state.

NOTE: The use of geotextile barrier fabrics surrounding the Primary Backfill material is considered good installation practice. The fabric must be chosen to allow the flow of water in and out of the excavation but to prevent the movement of fine soil particles into the Primary Backfill material.



### Burial Depth and Cover

1. The minimum cover with live load can be reduced, by using a reinforced concrete slab above the tank. Contact Aqua Solutions Ltd for details.

**Tank Minimum Cover (mm)**

Tank Diameter (mm)	With Live Load	Without Live Load
1800	900	500
2500	900	500
3000	1000	500
4000	1200	500

### Installation

Installation procedures must be in accordance with the Health and Safety at Work Act 1974, and other relevant legislation. Your procedures must also align with good building practice.

1. Excavation and anchorage provision in accordance with preceding information. Ground water must be pumped to give a dry excavation.
2. Place bedding material (primary backfill) as described in preceding information. Ensure material is clean and contains no oversize material.
3. Lift tank into position and align as required for connecting pipework, access shafts, etc.
4. Secure anchor straps, if used.
5. Commence backfilling in layers approximately 300mm, ensuring tank and any pipework is properly “haunched”.
6. Continue backfilling with select material evenly around the tank to at least 300mm above the tank top, connecting pipework, as required. Mount and seal any turret extensions.
7. Backfill evenly to grade using the same primary backfill material, OR select secondary backfill material or road base material.
8. Compaction should be by lightweight rollers or vibratory plate compactor until “traffic” depth has been achieved.
9. Compact evenly around the turret extensions to reduce risk of distortion.
10. Cut turret extensions to length and fit manhole cover and frame.
11. Important: Ensure that no surface loadings are transferred from the cover direct to the tank. Cover frame construction should allow movement.

### Access Shaft Extensions

1. Please note that loose shafts should be sealed using silicon sealant sikaflex –291 or similar prior to installation to prevent ingress of groundwater under high water table conditions. It is the contractor’s responsibility to ensure a watertight seal.