

Conder CNSB Bypass Separator: Concrete Surround

Premier Tech Aqua Installation Guidelines

Ref: UTG9503

Revision No. 4

General

1. These guidance notes refer only to the installation of Concrete surround CNSB Bypass Separators.
2. Manufactured to BS EN 858 Class 1 and Class 2.
3. These guidance notes cannot provide specific, site-related installation instructions.
4. If in any doubt whatsoever about any aspect of the installation please contact Premier Tech Aqua on 0870 264 0004.

Pre-Installation Inspection

1. The filter pod in these tanks is held in place during transportation by means of a Transit Brace. This is to hold the filter pod in place during transportation and ensure the separator is delivered to site in the same A1 condition as it left our manufacturing facility. **THIS MUST BE REMOVED PRIOR TO INSTALLATION.** Failure to remove the brace may prevent access to the pod for maintenance and **WILL RENDER THE WARRANTY ON THE TANK INVALID.**
2. The timber transit brace consists of a vertical brace holding the filter pod in place and a horizontal restraining bar. To remove the brace, unscrew the horizontal restraining bar and remove both pieces of timber.
3. Tanks should be subject to a visual inspection prior to installation
4. Check the tank is the correct size and duty, see label on tank
5. Any damage should be notified to the delivery driver and to Premier Tech Aqua on 0870 264 0004.
6. Do not attempt to carry out any unauthorised repairs, as this will invalidate the warranty on the tank.
7. Check for:
 - Fractures to the shell or ribs
 - Delaminations
 - Scratches or abrasions deeper than 1.5mm
 - Stress cracks or star crazing
8. Check invert depth is correct and inlet and outlet pipe orientations are correct
9. REMOVE TANK FROM PALLET

Service Specification

1. These tanks are designed to be installed below ground and completely surrounded with concrete.
2. Generally, the depth from finished ground level to the top crown of the main shell should be no more than 2 metres, this may vary dependent upon ground water conditions. Deeper inverts may be accommodated on a standard shell providing the water table level does not exceed 2 metres above the top crown of the main shell. For deeper burial with high water table conditions heavy duty shells are available. Should you be in any doubt regarding suitable shell application please call our sales number 0870 2640004. If the tank is installed outside these parameters it may suffer irreparable damage.

Concrete Specification

1. The specification for the concrete mix to surround the tank may be taken from BS 5328: Part 1: 1991 (including amendments), taking into account the site conditions and application requirements.
2. For a typical non-structural application in non-aggressive soils a Standard Mix ST4 with a 50mm slump is generally suitable, but also permits the equivalent Designated Mix GEN3 to be specified as an alternative. If for non-typical applications, structural or other reasons a higher than normal designation is required, the purchaser of the fresh concrete can use table 6 in BS 5328: Part 2: 1991 (amendment 8759/October 1995) for guidance.

Lift height (Rate of Rise)

1. Determine the lift height (m), or rate of rise (m/h) for the specific concrete type used, to ensure that a design pressure (P max) of 15kN/m² on the tank is not exceeded.

Vibration

1. The design of the tank assumes minimal compaction of the surrounding concrete. Where necessary, this may be extended to include light internal vibration. Never use deep revibration which will substantially increase the pressure on the tank, possibly causing failure.

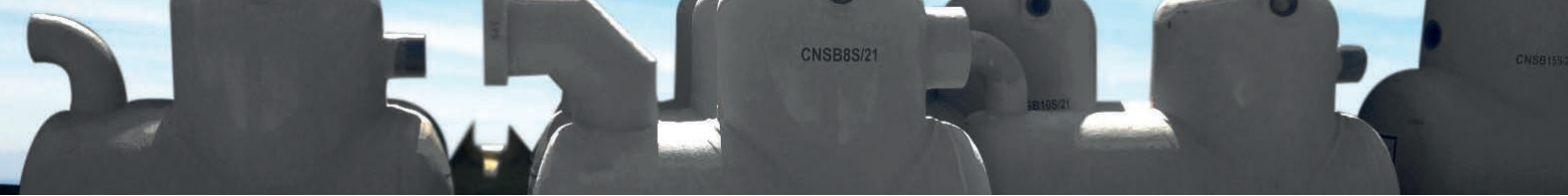

Impact of Concrete on Discharge

1. The effects of impact on discharge are considerable. These are controlled by the vertical form height, the tank diameter and the method of discharge. Under no circumstances should concrete be discharged directly onto the tank.

Loadings

1. If the tank is installed in an area where traffic or other superimposed loadings can be applied, consult a structural engineer for the design of a reinforced concrete slab to prevent the load being transmitted to the tank (or its concrete surround). If this slab is constructed immediately above the tank, it should be separated from the concrete surrounding the tank by a compressible material.

Transportation, Unloading and Storage of Tanks

1. Tanks must be held down during transportation using nylon straps, do not use cables or chains to hold tanks.
2. Do not over tighten straps to cause deformation of the tank shell.
3. Tanks are best lifted by crane and webbing lifting straps, do not use chains or wire ropes in contact with the tank.
4. Premier Tech Aqua recommends the use of a lifting beam for tanks longer than 8 metres.
5. Smaller tanks may be lifted with other suitable site equipment but greater care is needed to control the lift and to ensure the tank is not damaged.
6. Move tanks only by lifting and setting, do not drag or roll.
7. Do not drop or roll tanks from truck.
8. Place tanks carefully onto a smooth level even surface, free from rocks, large stones or other debris that could cause point loads.
9. Do not fill tanks or ballast with water whilst above ground, tanks are dependent upon support from concrete backfill to maintain the watertight integrity of the tank.
10. In high wind conditions, consideration should be given to strapping down the tanks to prevent damage.

Installation

Installation procedures must be in accordance with the Health and Safety at Work Act 1974, and other relevant legislation. Your procedures must also align with good building practice.

1. Excavate for the tank, allowing sufficient clearance for the minimum concrete surround thickness as shown in the table below, whilst also taking into account any shoring / trench supports used. The depth of the excavation is determined by the inlet and outlet pipe invert levels relative to the bottom of the tank, and allowing for the minimum base thickness shown. Dimensioned details of the separator can be taken from the relevant drawing. Ground instability at formation level e.g. running sand may necessitate over-excavation and stabilisation with hardcore or blinding concrete.

NOTE: Check that the depth to the base slab is within the Service Specification requirements for the tank.

Minimum Concrete Surround Thickness

Tank Diameter (mm)	'a' Minimum (mm)	'b' Minimum (mm)
1000	150	150
1200	150	150
1500	200	200
1800	250	250
2500	300	300
3000	300	300
4000	350	300

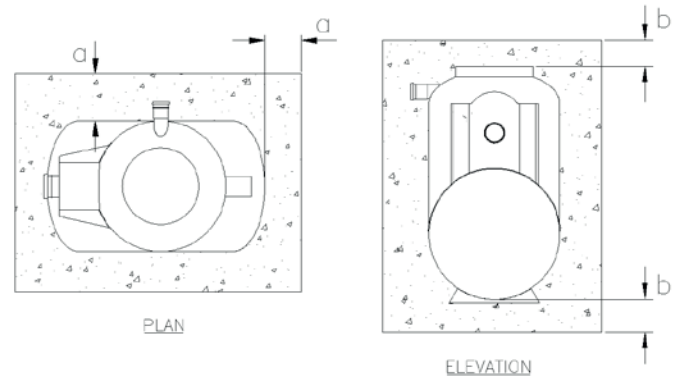

2. Maintain a completely dry excavation until the final pour of concrete has set. Failure to do this may result in voids beneath the tank and subsequent tank failure.
3. Pour the concrete into the bottom of the excavation to form a level and smooth base onto which the tank can sit. This should be to the minimum thickness given in the table above.

4. Place the tank onto the concrete base, while the concrete is still wet, and determine the correct orientation for the tank inlet(s) and outlet(s), i.e. the higher pipe on the tank is to be connected to your upstream (inlet) pipework, and the lower pipe on the tank is to be connected to your downstream (outlet) pipework. Connect and seal your pipework to the tank, checking alignment, and ensure that there is an adequate and correct fall for each pipe.
5. Fill the separator with clean water to a depth of 300mm and recheck the pipework levels. Commence backfilling evenly around the tank with concrete ensuring there are no voids, particularly at the bottom of the tank shell. Continue filling the chambers with water whilst evenly backfilling with concrete ensuring that the progressive water level is no more than 300mm above the concrete level.
6. Connect and seal any turret extensions prior to completing the concrete encasement of the main tank to the height shown in the table. Allow this concrete to set.
7. Using appropriate formwork, continue pouring concrete around the tank superstructure (i.e. bypass chamber, access turrets) in lift heights not exceeding 500mm, allowing initial set between each lift. Never increase the lift height or accelerate the rate of rise for the concrete type used, or allow the concrete to be compacted to an extent which will cause any part of the tank superstructure to distort. If you contravene this warning you will cause damage to the tank.
8. Complete backfill to ground level using free flowing material. Trim all access turrets and prepare suitable footings for each manhole frame ensuring that any loads on the covers are not transmitted to the tank access turrets or access extensions, if fitted.

Control of Groundwater

1. Tanks must not be subjected to buoyant forces during installation, taking account of ground water levels and surface water run-off, and their accumulation in the tank pit, even if tanks are anchored.
2. The excavation should be maintained dry by pumping or whatever suitable means until the concrete surround is cured.

Access Shaft Extensions

1. Access extensions shall be surrounded with concrete poured in 500mm lifts allowing initial set between each lift. The pressure from concrete placed in higher lifts may cause access extensions to distort or collapse.
2. Please note that loose shafts should be sealed using silicon sealant sikaflex -291 or similar prior to installation to prevent ingress of groundwater under high water table conditions. It is the contractors' responsibility to ensure a watertight seal.