

Conder Reinforced HDPE Septic Tank: Concrete Surround

Premier Tech Aqua Installation Guidelines

Ref: UTG9506

Revision No. 3

General

1. These guidance notes refer only to the installation of Premier Tech Aqua underground HDPE Septic tanks suitable for concrete surround.
2. These guidance notes do not provide specific, site-related installation instructions.
3. If in any doubt about any aspect of the installation please contact Premier Tech Aqua on 0870 264 0004.
4. Generally the depth from finished ground level to the inlet invert should be no more than 1m meters.

Transportation, unloading and storage of tanks

1. Tanks must be held down during transportation using nylon straps, do not use chains, cables or wire ropes to hold tanks.
2. Do not over tighten straps, causing deformation of the tank shell.
3. Ensure tanks are empty before attempting to lift or move.
4. Tanks are best lifted by utilising the moulded lifting eye and webbing lifting strap(s) as shown below – do not use chains, cables or wire ropes in contact with the tank.

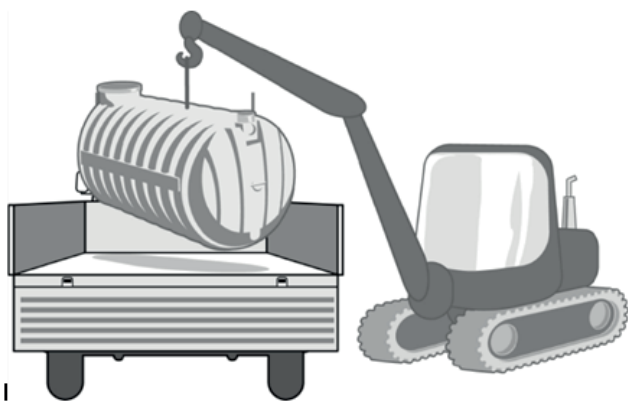

From 3 to 5m³, it needs 1 single nylon strap (1 handling ring)
From 6 to 12m³, it needs 2 nylon straps (2 handling rings)

5. It is recommended that a lifting beam is used for tanks longer than 8 meters.
6. Tanks may be lifted with suitable site equipment, but great care is needed to control the lift and to ensure the tank is not damaged.
7. Move tanks only by lifting and setting, do not drag or roll.
8. Do not drop or roll tanks from the delivery vehicle.

9. Place tanks carefully onto a smooth level even surface, free from rocks, large stones or other debris that could cause point loads on the tank shell.
10. In high wind conditions, consideration should be given to strapping down the tanks to prevent damage.

Pre-Installation Inspection

1. Tanks should be subject to a visual inspection prior to installation. Special consideration should be given to strap positions. Check for any signs of impact damage to the main shell and other components.
2. Any damage should be notified to the delivery driver and to Premier Tech Aqua.
3. Do not undertake any unauthorised repairs, as this will invalidate the tank warranty.
4. Check the invert depth is correct, the tank is correct grade for concrete surround and that the inlet and outlet pipe orientations are correct
5. Where present, all fixings (nuts, bolts, screw fixings etc) should be checked and retightened to correct any movement during transport. Premier Tech Aqua do not accept responsibility for fixings that have not been checked prior to the tank entering service.

Excavation

1. Excavations should be planned with due regard to Health and Safety requirements, and should be either shored or battered back to a "safe" angle.
2. The excavation should allow for the minimum concrete surround thickness (tank sides /ends and base) as shown in the table below, while taking into account any shoring used.
3. Ground instability at formation level e.g. running sand, may necessitate over-excavation and stabilisation with hardcore or blinding concrete.

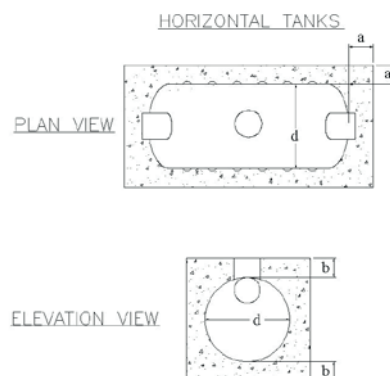



Tank Diameter (mm)	'a' Minimum (mm)	'b' Minimum (mm)
Millenium R 3m3	150	150
Millenium R 4m3	150	150
Millenium 5m3	150	150
Millenium 6m3	200	200
Millenium 8m3	200	200
Millenium 10m3	200	200

Buoyancy and Anchoring

1. The dimensions, in the above table, may need to be increased if there is a risk of high ground water level at the tank location. To avoid floatation we recommend a factor of safety of 1.5 against floatation. Mass concrete has a minimum density of 2,300 kg/m³

Concrete Specification

1. The specification for the concrete mix to surround the tank should be selected by the tank installer taking into account the site conditions and application requirements.
2. For a typical non structural application in good ground conditions, with non aggressive soils, a concrete with a 28 day compressive strength of 20 to 30N/mm² with a 25 to 50mm slump, complying with the relevant BS EN, is generally suitable. For non typical applications, aggressive soils or structural applications specialist advice should be obtained.

Lift height (rate of rise)

1. Determine the lift height (m), or rate of rise (m/h) for the specific concrete type used, to ensure that a design pressure (P max) of 15kN/m² on the tank is not exceeded.

Vibration

1. The design of the tank assumes minimal compaction of the surrounding concrete. Where necessary, this may be extended to include light internal vibration. Do not use deep revibration which will substantially increase the pressure on the tank, possibly causing failure.

Impact of Concrete on Discharge

1. The effects of concrete discharge impact are considerable. These effects must be considered to ensure the maximum pressure of 15kN/m² on the tank is not exceeded. Under no circumstances should concrete be discharged directly onto the tank.

Live Load

1. If the tank is installed in an area where traffic, or other superimposed loadings can be applied, a structural engineer should be consulted, to design a reinforced concrete slab spanning over the tank. This is to prevent the load being transmitted to the tank (or its concrete surround). If this slab is constructed immediately above the tank, it should be separated from the concrete surrounding the tank by compressible material.

Tank Burial Depth

1. This grade of tank is designed to be installed below ground and completely surrounded with concrete.
2. Generally, the depth from finished ground level to the inlet invert should be no more than one metre. If the tank is installed outside these parameters it may suffer irreparable damage. Should you be in any doubt regarding suitable shell application please contact Premier Tech Aqua.

Control of Groundwater

1. Tanks must not be subjected to buoyant forces during installation, taking account of ground water levels and surface water run-off, and their accumulation in the tank excavation.

Installation Procedure

1. Maintain a completely dry excavation until the final pour of concrete has set. Failure to do this may result in voids beneath the tank and subsequent tank failure.
2. Place the concrete in the base of the excavation to form a level and smooth base onto which the tank can be placed. The base concrete thickness should be in accordance with the information provided above.
3. Place the tank onto the concrete base, while the concrete is still wet, and determine the correct orientation for the tank pipework. Connect the pipework to the tank, ensuring correct alignment.
4. Fill the tank with clean water to a depth of 300mm and recheck the pipework levels and connections. Commence backfilling evenly around the tank with concrete ensuring there are no voids, particularly at the bottom of the tank shell. Continue filling the tank with water whilst evenly backfilling with concrete around the tank ensuring that the progressive water level is no more than 300mm above the concrete level.



5. Connect and seal turret extensions prior to completing the concrete encasement of the main tank (the height shown in the above table). Allow the concrete to cure. The turret extension should be trimmed from the bottom to the required height before connection to the tank.
6. Using appropriate formwork continue pouring concrete around the tank superstructure, i.e. access turrets, in lift heights not exceeding 500mm, allowing the concrete to set between each lift. The lift height, rate of concrete rise, or concrete compaction must not be to an extent which causes any part of the tank superstructure to distort, as this will damage the tank.
7. Complete the backfill to ground level using free flowing granular material. Ensure the cover and frame(s) are correctly secured.

Access Shaft Extensions

1. Access extensions should be surrounded with concrete poured in 500mm lifts, allowing an initial set between each lift. The pressure from concrete placed in higher lifts may cause access extensions to distort or collapse.
2. Loose shafts should be sealed using silicon sealant, sikaflex -291, or similar prior to installation to prevent ingress of groundwater under high water table conditions. It is the installation contractor's responsibility to ensure a watertight seal.

Threaded inspection points/Ventilation

1. The red/green threaded inspection/rodding points above the inlet connection are not required for the UK/ Irish market. Rodding access should be provided at the upstream manhole and these threaded covers should be securely tightened and backfilled with the tank.
2. Septic Tank ventilation would generally be via the stack pipes on the property/properties served or a remote vent taken from the inlet drainage line.